

ZESTAWIENIE STALI ZBROJENOWEJ

ZBROJENIE WARSTWY OCHRONNEJ.

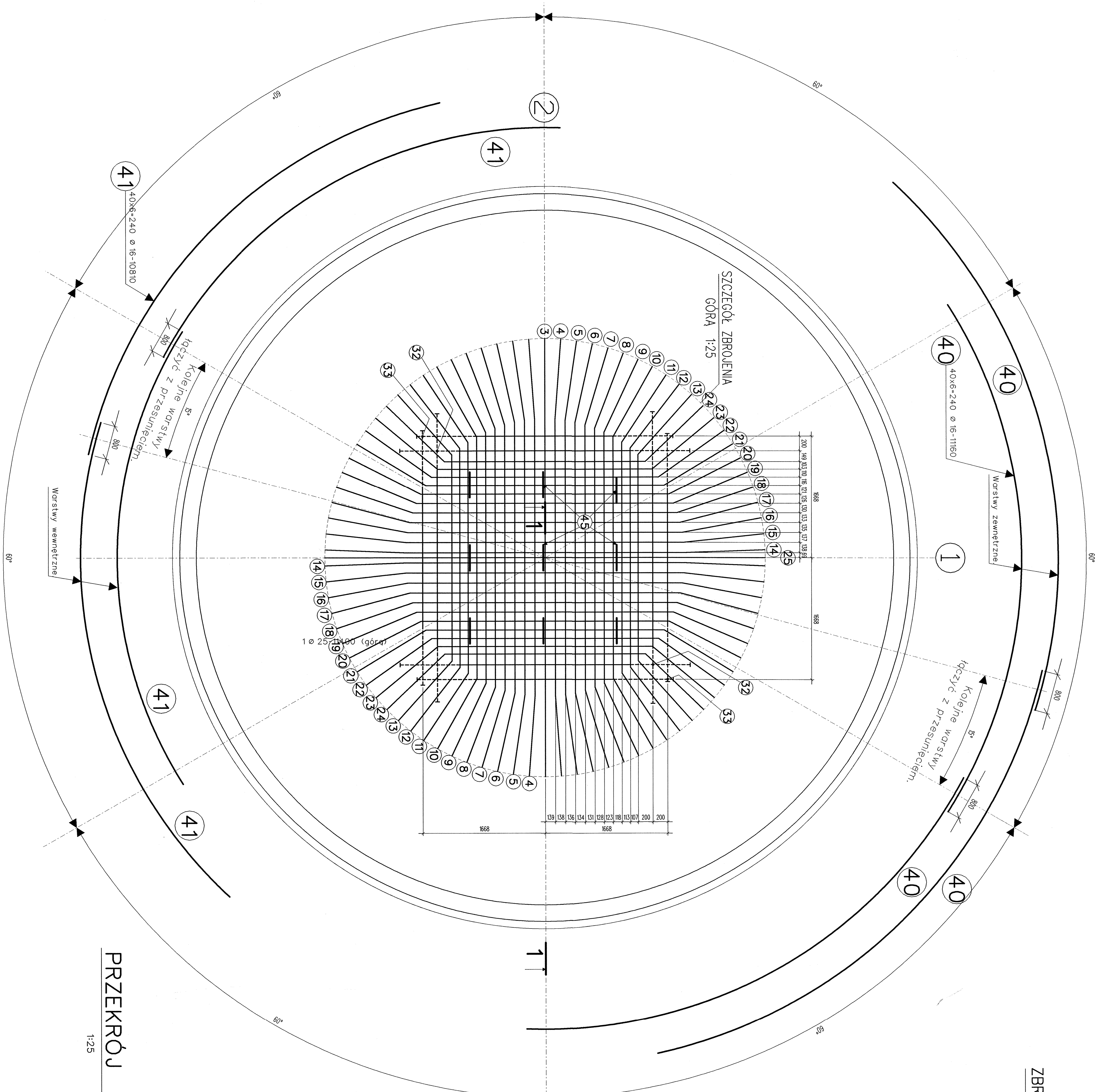

PRZEKRÓJ 1-1

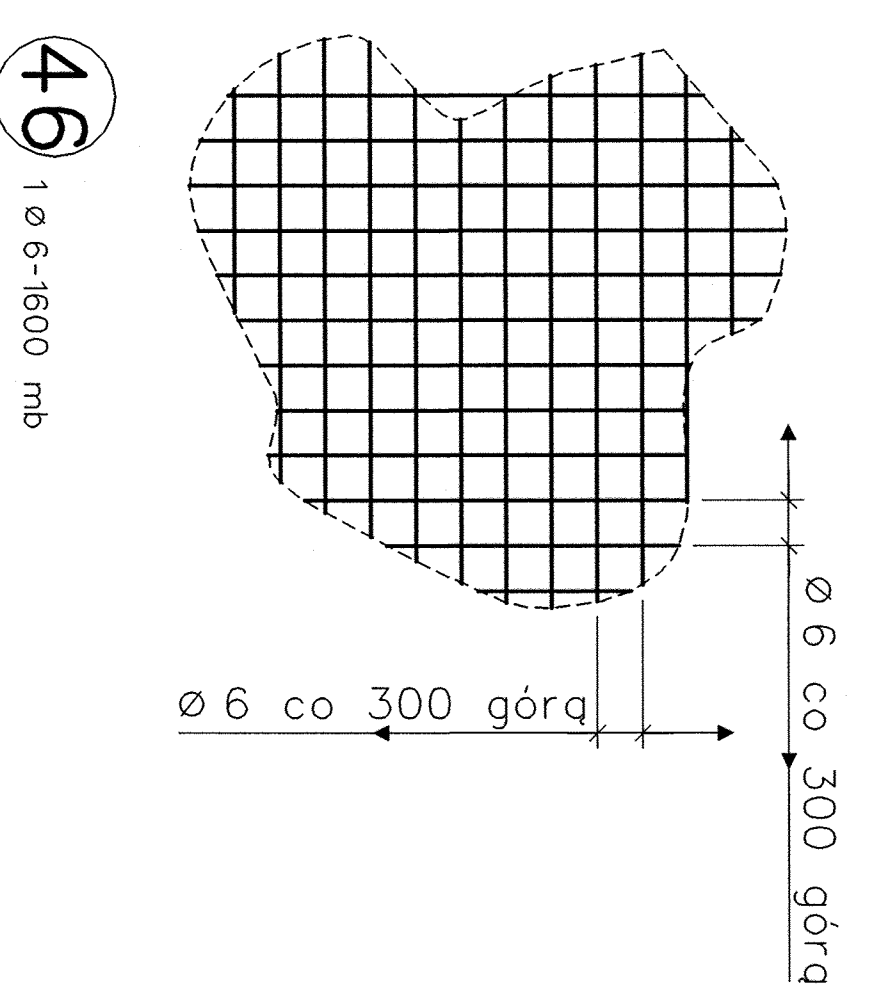
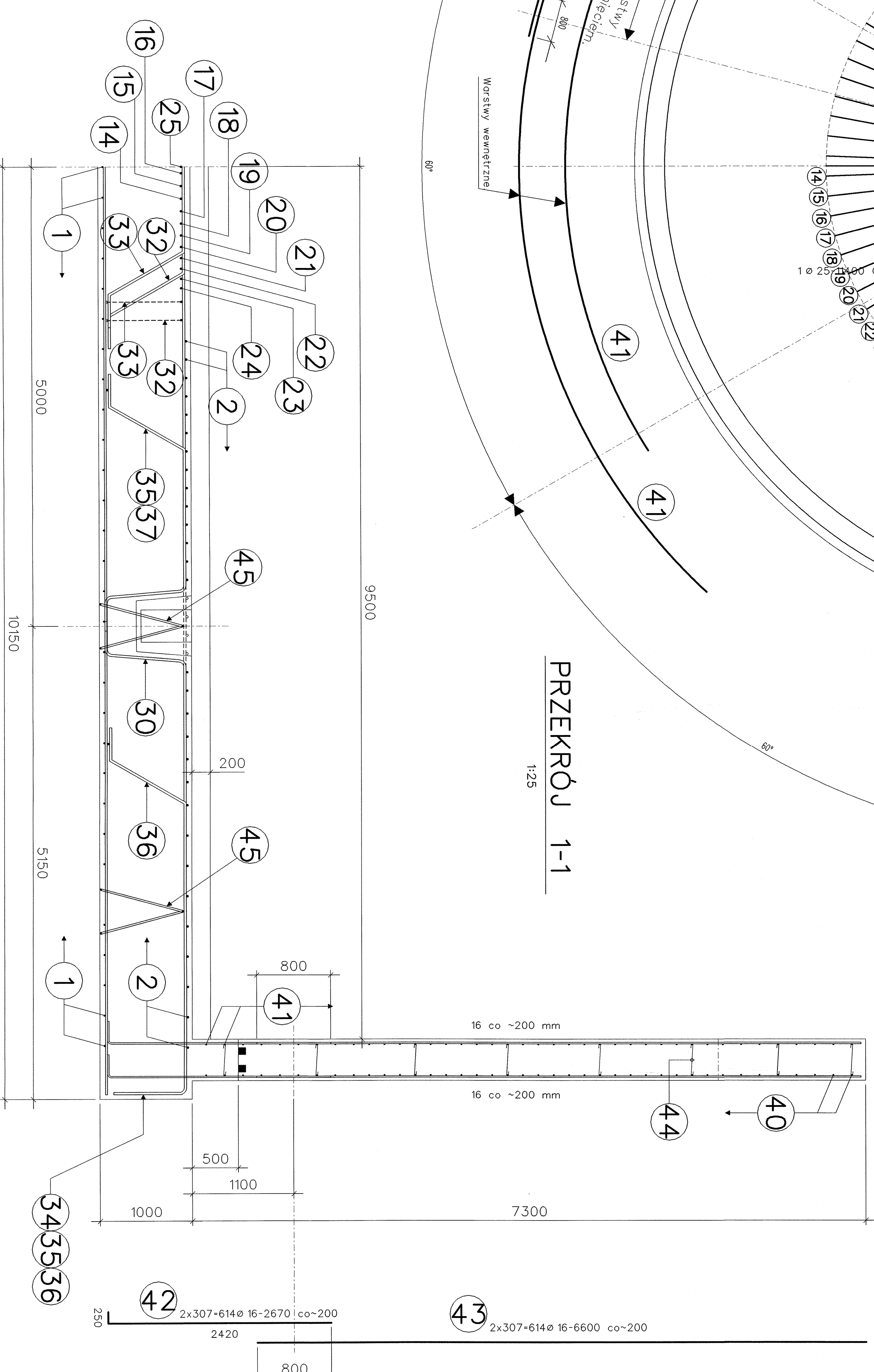

Zbiornik zespolony.

ELEMENTY	NAZWA	LICZBA	DŁUGOŚĆ	ROZMIAR I LICZBA PRĘTÓW ZBROJENIA			DŁUGOŚĆ OGÓLNA	
				W-1-W	Ø 6	Ø 6		Ø 20
NR	PRETA	ŚREDNICA	DŁUGOŚĆ	ELEMENTY	Ø 6	Ø 6	Ø 20	Ø 25
STUK	mm	mm	m	STUK	kg	kg	kg	kg
1	20	12,000	34	34				
2	25	12,000	92	92				1104,0
3	25	9,260	1	1				9,3
4	25	11,390	2	2				22,8
5	25	11,360	2	2				22,7
6	25	11,309	2	2				22,6
7	25	11,239	2	2				22,3
8	25	11,149	2	2				22,1
9	25	11,041	2	2				21,8
10	25	10,914	2	2				21,5
11	25	10,769	2	2				21,2
12	25	10,608	2	2				20,9
13	25	10,430	2	2				20,7
14	25	11,397	2	2				22,8
15	25	11,377	2	2				22,7
16	25	11,337	2	2				22,6
17	25	11,276	2	2				22,4
18	25	11,196	2	2				22,2
19	25	11,097	2	2				22,0
20	25	10,979	2	2				21,7
21	25	10,844	2	2				21,4
22	25	10,690	2	2				21,0
23	25	10,521	2	2				20,7
24	25	10,336	2	2				20,2
25	25	11,400	1	1				11,4
26	27	-	-	-				-
27	25	0,125	392	392				49,0
28	29	0,100	294	294				29,4
29	20	6,750	6	6				40,5
30	25	1,880	8	8				15,0
31	20	4,930	4	4				19,7
32	25	4,470	4	4				17,9
33	25	5,190	84	84				436,0
34	25	9,125	80	80				730,0
35	25	5,275	60	60				316,5
36	20	2,800	35	35				98,0
46	6	1600,000	1	1				1600,0
DŁUGOŚĆ OGÓLNA WG ŚREDNIC			m	1830,0				3213,1
MASA 1m PRETA			kg	0,222				3,850
MASA PRETÓW WG ŚREDNIC			kg	406				17324,4324
MASA PRETÓW WG RODZAJÓW STALI			kg	406				12371
MASA CAŁKOWITA			kg					34425

BETON B30
STAL A-I/A-II/A-III

Stopień wodoczułości-III6

UWAGI:
1.PATRZ - RYSUNEK ZESTAWCZY ZBIORNIKA ZESPOLONEGO.

Przedmiot rysunku: **Zbiornik zespolony.**
Rys. Zbiornikowy-Akusz II.
cz. Biurobiłwa

Wykonanie: **Mechanizmo-biologiczna oczyszczalnia ścieków w KAMIENICZY POLSKIEJ**

Projektant rysunku: **ZAM Z**

Wzrost: 1,90
Ciężar ciała: 75
Data: 12.12.2011

Wykonanie: **ZAM Z**

Wzrost: 1,90
Ciężar ciała: 75
Data: 12.12.2011